

SALES DRAWING SALES DRAWING

SALES DRAWING

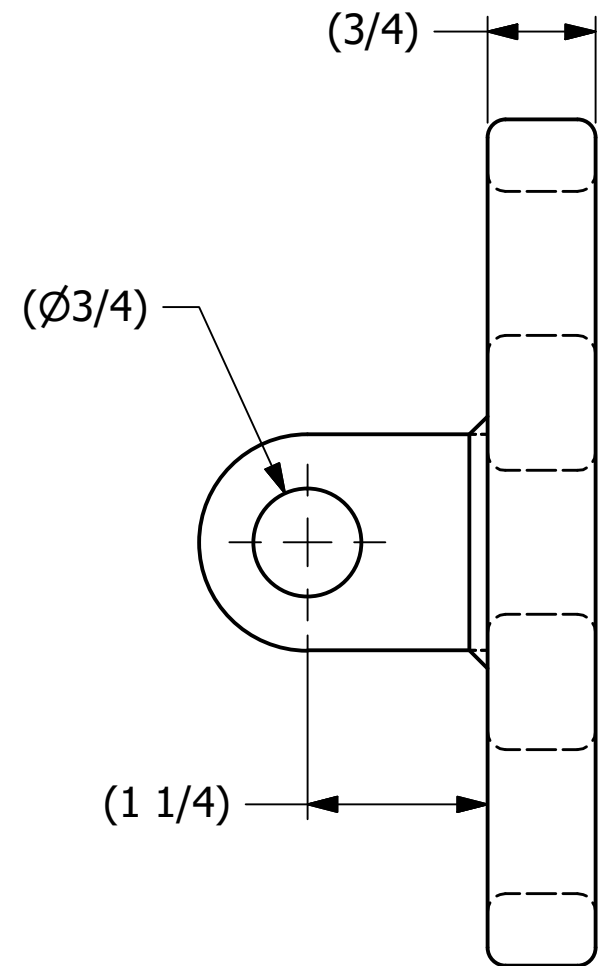
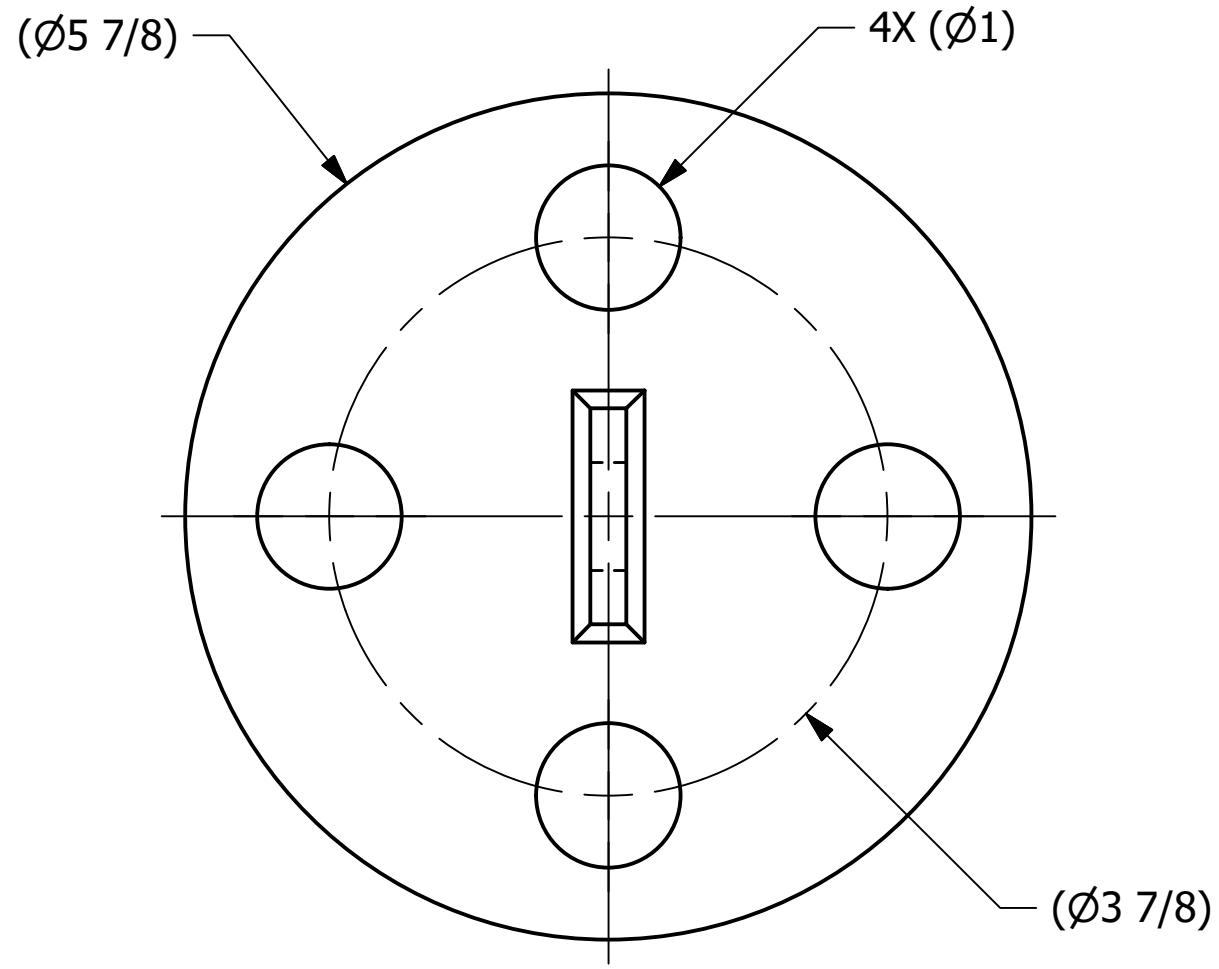

B	CHL	6/13/22	202206130806	CHL
REV	BY	DATE	REF #	PUB

<small>UNLESS OTHERWISE SPECIFIED DIMENSIONAL TOLERANCES</small> FRACTIONAL: $\pm 1/16$ X.XX: $\pm .03$ X.XXX: $\pm .015$ ANGULAR: $\pm 1^\circ$ <small>DEBURR ALL SHARP EDGES. ALL MACHINED SURFACES TO HAVE A 125 RMS FINISH UNLESS NOTED OTHERWISE.</small>	DRAWN BY:	VD
	CHECKED BY:	
	PROTOTYPE DATE:	5/13/2010
	APPROVED FOR PRODUCTION BY:	VD
	PRODUCTION DATE:	6/23/2010
THIRD ANGLE PROJECTION	SIZE:	B
	DRAWING #:	28722

PART NAME:		
BLIND FLANGE 3 7/8"		
MATERIAL: ASTM A36 CS		
PROJECT #: WAG0829	SHEET #: 1 OF 1	SCALE: 3 : 4
PART #:		
BF3875HCL		